

[www.pintsch.net](http://www.pintsch.net)



Level crossing technology.  
Safe. Reliable. Capable.



Fü-RU  
relay converter

# Fü-RU relay converter

## Applications

PINTSCH has developed the Fü-RU relay converter as a lower-cost alternative for the transmission of Fü interface information from level-crossing control systems across distances greater than 6.5 km to the signal cabin (interlocking tower). To optimise interference lengths, this module can be installed in the signal cabin (interlocking tower), in the level-crossing control system or in the wiring cabinet. Corresponding verification by means of interference calculation (BFB) is necessary as an element in PT1 planning in all cases.

## Structure

The converter features a display on its front panel. Electrical connection of the module is accomplished by means of plug-type connectors on the upper and lower sides of the insulating housing. The housing is mounted on a top-hat mounting rail.

## Function

Constant conditions in order to permit transmission across distances of more than 6.5 km are made possible in the Fü-RU relay converter on the basis of constant current sources on the cores of the Fü interface in the lineside cables. Under ideal conditions, a maximum actuation distance of 32.5 km is thus possible with a core diameter of 1.4 mm.



Fü-RU  
relay converter

### Features:

- Compact design
- Use with Fü interface
- For actuation distances of more than 6.5 km
- And/or for electrical isolation under unfavourable conditions
- Installation in the signal cabin, level-crossing control system or wiring cabinet

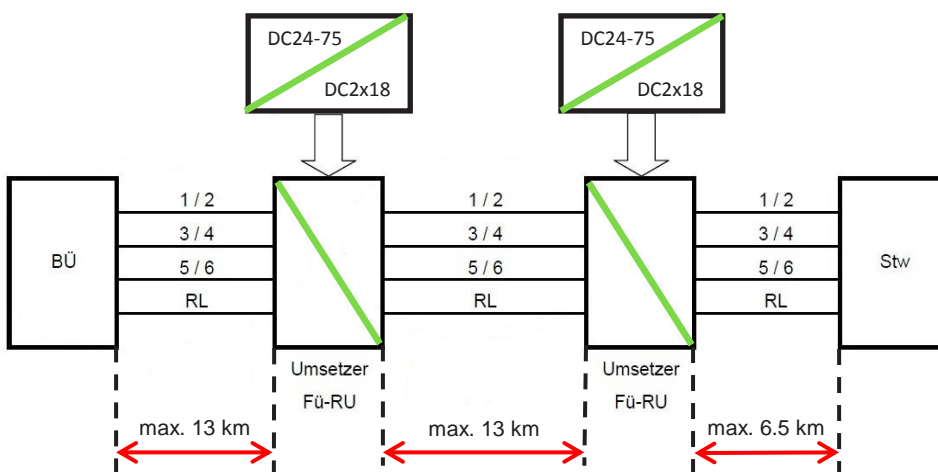

088 027 812-000 (12.13 en)

# Fü-RU relay converter

## **Power supply**

This relay converter is designed for supply voltages of 60 V DC (signal cabin) and 36 V DC (level-crossing control system or wiring cabinet). The use of a DC 24-75/2x18 DC-DC converter is necessary in all cases. Relay converters and DC-DC converters cause electrical isolation, with the result that appropriate configuration will permit reduction of interference lengths.

Subject to technical changes



**PINTSCH GmbH**  
Hünxer Str. 149  
46537 Dinslaken  
Germany

T +49 20 64 602-0  
F +49 20 64 602-266

info@pintsch.net  
www.pintsch.net